

# The Application of Fine Sprays for Chemical, Biological, and Radiological or Nuclear (CBRN) Decontamination

G.G.Nasr<sup>1\*</sup>, A.J. Yule<sup>1</sup>  
S.E.Lloyd<sup>2</sup> and A. Whitehead<sup>2</sup>

<sup>1</sup>Spray Research Group  
Institute of Materials Research (IMR)  
School of Computing, Science and Engineering (CSE)  
University of Salford, Salford  
Manchester M5 4WT  
United Kingdom

<sup>2</sup>Hughes Safety Showers (HSS) Ltd  
Whitefield Road, Bredbury, Stockport, SK6 2SS,  
United Kingdom

## Abstract

The risk of exposure to hazardous materials, in many industrial environments and in everyday life due to the possibility of terrorist attacks, is widely recognised. It is therefore pertinent to have robust decontamination equipment to limit the effects of hazardous materials and in turn protect human life and assets. This can be done by the application of neutralisation (coverage) and rinsing techniques to the hazardous materials. The overall aim of this paper is to describe an investigation utilising fine sprays for coverage/deposition on the human body, in conjunction with standard safety showers for rinsing of a victim during decontamination of CBRN materials. As a novel feature miniature high pressure spill-return atomiser are used. It was found that fine sprays decrease the consumption of decontamination liquid that is normally used in practice which has many advantages in practice.

## Introduction

### Background

Chemical, Biological, and Radiological or Nuclear (CBRN) materials can be classed into four main types of hazards: contact, inhalation, injection and ingestion. Chemicals are loosely classified by their action in the body: nerve agents, blister agents, lung damaging agents, and gaseous cyanides. For example Ricin is a potential chemical agent which could be used by terrorists. The castor plant beans from which Ricin is obtained are readily available. Biological agents include viruses, bacteria, fungi, prions (proteinaceous infectious particles that lack nucleic acid) and parasites. Radiological agents have two hazards: external exposure from radiation emissions, and internal exposure from absorption of material into the body. The release of nuclear agents would result from a nuclear accident (from a nuclear power station, waste processing plant or nuclear waste storage facility) or the transport of nuclear material. The sources of contamination can be split into two sections: intentional and unintentional release. Each section can be further divided into whether the incident had prior warning to allow the pre-deployment of resources. Intentional release includes terrorist attacks, and military actions (in peacetime and wartime). Unintentional releases are materials in transit e.g. road tankers, rail cargo, air cargo, laboratories, hospitals, industrial and commercial sites (e.g. swimming pools, dry cleaners, etc). This

investigation focuses on the removal of materials to limit the hazards associated with the contact, inhalation and ingestion of the contaminant. This is achieved by a combination of the removal of the contaminant from the skin and by neutralizing the contaminant whilst on the skin to render the hazard safe.

### Current decontamination methods

The *bucket and sponge* is a simple system that produces a medium level of wasted water as the water and neutralising agent in the bucket must be changed and the sponge must be changed after every person to avoid contamination from the sponge. Victims must still be rinsed both before and after the wiping, as recommended in the UK Home Office National Strategic Guidelines. This method leads to a high amount of contaminated water and is crude and unreliable.

The *military wipes* method is unlikely to be suitable for mass-decontamination.

*Foams* like Sandia National Laboratories SNL100 and Modex Decon Foam MDF200 may be used to treat biological agents in addition to current uses as fire suppressants and for riot control. The foams are created by drawing the liquid through a nozzle using compressed air and they are undergoing testing and development to observe the efficiency in real world applications [1].

*Electrostatic* sprays are under development at the University of Georgia USA [2].

\* Corresponding author: g.g.nasr@salford.ac.uk  
Associated Web site: <http://www.cse.salford.ac.uk/srg>  
Proceedings of the 21<sup>th</sup> ILASS - Europe Meeting 2007

Figure 1 is a schematic arrangement of the decontamination systems that are currently in use for both non-ambulatory and ambulatory situations. The system typically uses 100 l/min of water per stage. According to UK Home office information for both treatment (chemical) and rinse showers stages, 90 litres per person is recommended for complete decontamination. The system uses standard safety ‘shower head’ nozzles in both Treatment and Washing (Safety Showers) zones, where the Treatment stage includes a solution of an agent to help neutralise and disperse the hazard. The shower heads are connected to a mains water supply and thus have large orifices (several mm) giving high flow rate at only a few bar pressure. The large amount of water that is used must be contained and treated after the incident. This practice thought to be cumbersome and expensive both logistically and operationally.

Pre-Robing	Treatment	Safety Showers	Re-robing
Staff	Staff	Staff	Staff
F E	M A	L	E Lane

Arrangement-1

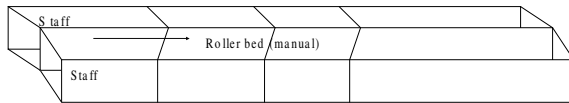

Arrangement-2

Figure 1 Schematic arrangements of current decontamination systems using safety showers

### New approach used here

In practice the Treatment (Neutralising) stage requires deposition of agents on the body and the aim here is to use fine sprays at low flow rates (rather than the high flow rate showers currently used in this stage). The use of fine sprays should result in the need for smaller volumes of water, which is particularly important because the sprayed water must be subsequently collected and treated. The authors considered options for making fine sprays at low flow rates (e.g. < 0.2 l/min). Specially manufactured miniature high pressure swirl atomizers were developed [3, 4] producing narrow angle sprays (<40°). It is noted that although the atomizers produced *hollow cone* sprays near the exit orifice, rapid diffusion due to the small drop sizes, gave *solid cone* sprays within several cm downstream. These atomizers incorporated *spill return* systems so that spray flow rate could be controlled with little effect on drop size.

Other potential advantages of this fine spray system over competitive decontamination showers are: (1) the possibility for recycling water during treatment via filters

(this is possible due to the relatively low flow rates compared with conventional systems), (2) the low impact momentum of individual droplets in the spray, so any injuries (like fresh cuts, grazes, etc) would not be affected by the fine sprays, (3) the possibility of retrofitting existing shelters with the new technology, (4) ease of use in areas in which the access to water is restricted or limited (such as deserts, battlefields, etc).

The main objectives of the project are: (a) to determine the feasibility of using the fine sprays produced by these atomisers in the treatment section of a mass decontamination delivery system, (b) to find the required number, orientations, flow rates and positions of atomisers that will provide complete coverage of a of human body, (c) to explore minimisation of the time needed for effective total coverage, (d) to carry out repeatability tests in ensuring consistency of the obtained data, and (e) to explore the effectiveness of the same atomisers in the role of second stage rinsing of the body.

### Apparatus

The coverage/deposition and the rinse trials were carried out in a test chamber based at Hughes Safety Showers Limited as shown in Figure 2. The test chamber comprised of 8 spill-return atomisers for coverage and 5 standard Hughes nozzle-type [5] safety showers for rinsing. A mannequin was used in simulation of a human subject.

The test rig was made of frame box section aluminium with grooves that allow the vertical movement of the atomisers and the standard safety nozzles. The dimensions of the chamber were: Height: 2.44m, Width: 1.18m and Depth: 1.41m. Perspex sheet was bolted onto the rear and sides of the frame for containment of the sprays. Entry to the test chamber was permitted by flexible plastic flaps. The floor covered by a grate which allows waste liquid to collect in a sump whilst preventing the occupant from standing in it. Figure 2 shows the layout of the flow system for the fine spray spill return atomizers.

The results of this work will, eventually, be used in constructing decontamination systems, as illustrated in Figure 3. These will either be rectangular shaped chambers or inflatable tent types, variations of which already exist. Victims would enter from the contaminated zone to a disrobing area in which the contaminated clothes and possessions are removed and bagged and labelled. The victim would then proceed through a sealable door into the treatment section using the fine spray technology. This project determines the spray time and positioning needed for total effective coverage. Dependant upon the chemical contact time, the victim would remain in the treatment stage for a set time and then proceed through a sealable door into the rinsing section. Once the victim has been rinsed, they are directed through another sealable door to a re-robing section where the victim is given a

clean set of clothing, similar to the current system, shown in Figure 1.

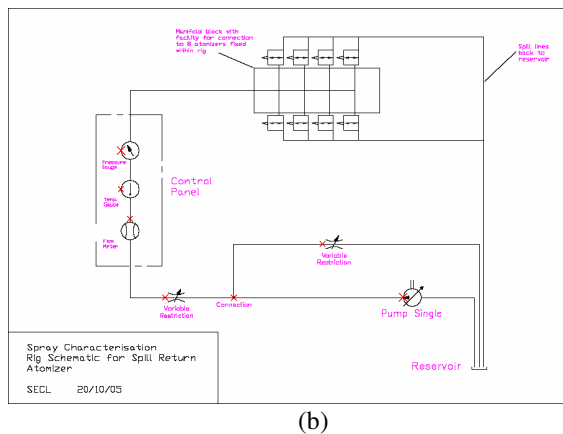
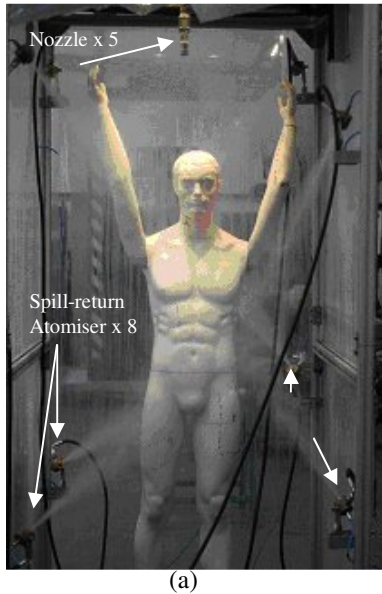

Figure 2 Test chamber with mannequin (a) and (b) the fine spray flow system

As illustrated in Figure 4, eight fine spray liquid pressure swirl atomisers [3, 4] with spill-return capability, are used in this investigation for coverage/deposition. The atomisers typically produce sprays with droplet sizes of between  $17\mu\text{m} < D_{32} < 22\mu\text{m}$ , at 0.55 l/min to 0.05 l/min flow rate (according to the % spill return) and typical liquid pressure of 90-120bar.

The test rig also has 5 standard high flow rate Hughes nozzles [5] which were used for rinsing and located in the following configuration: one nozzle at 2m (directly overhead), two diagonally opposite nozzles at 1.7m (at positions 1 and 5), two diagonally opposite nozzles at 1m (at positions 7 and 6). Each nozzle sprayed water, at flow rate of 3 l/min and pressure of 2.5bar, giving a total flow

rate of 15 l/min. The sprays typically had a volume median diameter of the order 1mm. The nozzles and the atomisers are mounted on brackets which permitted the alteration of the angle of the spray. The angle  $\alpha$  is measured from the front and rear walls and the angle  $\gamma$  is measured from the horizontal plane as shown in Figure 5.

## Procedures

### Coverage/deposition

The coverage tests aim to ascertain the effectiveness of the fine spray atomisers in providing coverage to neutralise the contaminant agents using the mannequin. Furthermore, these tests provided information on the required number and positioning of the atomisers inside the test chamber. The quantitative level of coverage or deposition was measured by using high absorbency paper which was cut into two sizes, weighed and then placed onto specific sites on the mannequin.



(a)



(b)

Figure 3 Proposed decontamination systems (a) chambers and (b) typical HSS Ltd tents

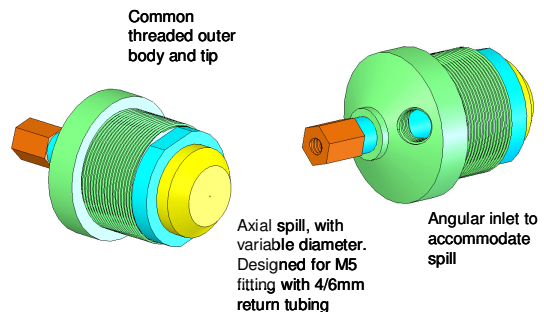

Figure 4 High pressure, low flow rate swirl atomiser with 0.3mm exit orifice

The smaller size paper was used in locations L, M and N, as shown in Table 1. Tests were also conducted by using blue food dye which provided a clear visual indication of the coverage of the mannequin. The spray and spill flow rates of each atomiser were measured by collection methods.

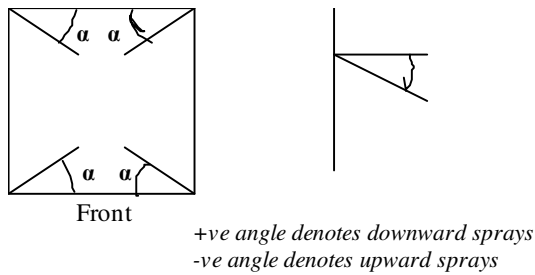

Figure 5 Orientations and angles of the fine spray swirl atomisers and the Hughes safety shower nozzles in the test chamber

**Repeatability tests**

Repeatability studies were performed at the better configurations, at one spray duration time to establish the consistency of performance of the sprays in terms of coverage.

**Rinsing tests**

The mannequin was completely covered in talcum powder and each spray system was switched on for 5 minutes to simulate the likely time frame of real life operation. The water tank contained blue food dye and this was deposited on the mannequin and mixed with the talcum powder to make a blue residue. Any residue that was left on the manikin after 5 minutes was talcum powder that was not rinsed off. A series of images using an EOS 350 D Cannon digital camera were taken before the test and after the test for qualitative examination.

**Results and Discussion**

**Coverage/deposition**

Initial trials were conducted for best locations for the fine spray atomisers inside the test chamber and the required numbers to provide full coverage. Results showed that with 4 atomisers poor all round coverage was achieved, as the back shoulder blade, left arm, shoulder and upper outer arm and the legs were not covered. The use of 6 atomisers also gave unsatisfactory coverage however it may be possible to use 6 atomisers when the victim performs a specified rotation in the treatment section. It was generally found that the required minimum number of atomisers is 8, which provided reasonably even coverage when the atomisers were as shown in Figure 6. This configuration had atomisers located at heights

between 0.6 to 2.2m, and angles of  $\alpha= 45$ -60 degrees and  $\gamma=30$ -45 degrees (see also Figure 5).

A	Back of head
B	Left upper shoulder
C	Right torso
D	Inside left arm
E	Left front, upper thigh
F	Left rear, lower leg
G	Right outside, upper thigh
H	Right upper foot
I	Right neck
J	Right upper leg and groin
K	Top of head
L	Right underarm
M	Left shoulder
N	Right hand

Table 1 Locations for decontamination tests (arms are raised)

As shown in Figure 7 streaking could occur under some conditions. Where streaking occurs over a surface that has not been covered with droplets, this must be avoided and misleading results can then be obtained when using the absorbent paper method if care is not taken.

Figure 8 shows an example of a comparison using different spill return rates where flow rates and spill orifice sizes are shown in Table 2. The total flow rate for the configuration with 0% spill return is thus  $8 \times 0.55 = 4.4$  l/min.

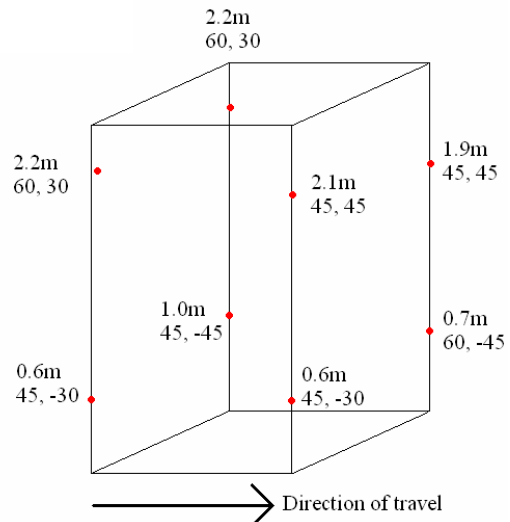

Figure 6 A fine spray configuration for effective total coverage.

Spill orifice diameter (mm)	Spray flow rate (l/min)	Exit orifice diameter (mm)
0.0	0.55	0.3
0.4	0.30	0.3
0.7	0.13	0.3
0.8	0.11	0.3

Table 2 Characteristics of different spill return set-ups

The comparison of coverage results in Fig 8 is shown on the basis of the % increase in weight of each sampling paper, due to deposition. The required deposition mass per unit area for an agent is not known *a priori* and will depend upon the material hazard that is being neutralised, or prepared for washing off, during the rinsing stage. However if one takes a 200% increase in the paper weight as a guide to what is required, the time trials have indicated that the lowest time for effective

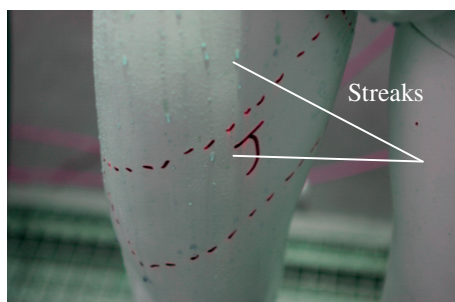

Figure 7 Streaking effects on the upper thigh of mannequin

coverage is 15 seconds and this occurs for the zero spill return case. However this is mainly due to the higher spray flow rate for this case and it is found that with a decrease in spray flow rate (by opening up the spill return), with the same spray duration, the decrease in deposition is less than in proportion. This shows that there are set-ups for the spill return atomizer that will optimise the total of volume of water sprayed. The data in Fig 8 show that there are “hot spots” and “cold spots” in the coverage. Thus the spray positioning is not optimum. Furthermore there is scope for using more than 8 atomizers in order to more uniformly cover the body but using high spill returns for some of them so that the total flow rate may be equal or less than that for the 8 atomizers: an ideal configuration will have each atomizer with its own setting for the spill return so that, for example, zero spill return is needed for good penetration to difficult zones, whilst the more straightforward zones for coating have high spill return rate atomizer directed towards them.

By measuring the collected water it was found that 45-50% of the water was retained as coverage on the body surface. This compares with only 2% for current systems for which run-off is typically 98% of the applied solution at high flow rates according to the UK Home Office National Strategic Guidelines.

In a simplistic comparison with the conventional case using showers in the treatment section, when using 8 zero spill fine spray atomizers the treatment section will need to be switched on for 15 seconds giving a total sprayed volume of 1.1litres of which 50% is deposited on the victim. In the current system, however, in the treatment section with neutralising agent (for known chemical), 5 litres of the solution is used.

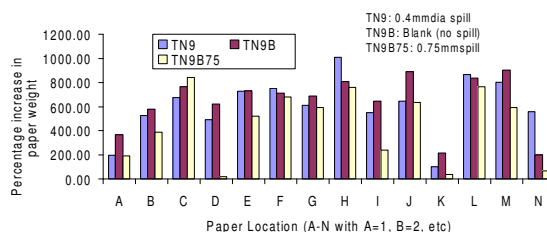

Figure 8 Comparison of coverage using different spill return rates for 30 seconds

The repeatability results for replicate experiments spraying for the same duration showed overall that the consistency of the coverage was acceptable. It can be seen in Figure 9 that the percentage increase in the paper weight did vary however this could be explained by the fact that the path taken by the water that streaked down the body is not always the same.

There are many factors that affect the path taken by water as it streaks down the body, such as the surface texture, body ‘wetness’, local air currents, the non-uniformity of the spray, etc. The average percentage increase for all positions varies from 592 to 644%. More importantly, the minimum percentage coverage ranges from 188% to 222% for the different replicate experiments. The importance of this is clear as the lowest percentage coverage gives an indication of the minimum amount of liquid neutralising agents deposited on the mannequin. It is emphasised that, as described above, the set up used in these tests is not the optimum and it is thought that an improved set up, with more equal deposition at each position, would also reduce the variations produced for replicate spray tests.

### Rinsing

The spill-return atomisers, even when used in absence of spill and at 120 bar supply pressure, were found to be unsuitable in a rinsing role, as this requires high local liquid flux. A blue residue of the talcum powder remained on the body of the mannequin as illustrated typically in Figure 11(b).

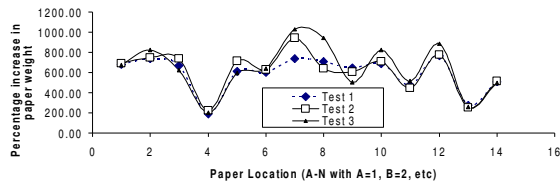

Figure 9 Typical repeatability coverage trials for 30s

The five standard HSS nozzles were used, and it was found that all the talcum powder from the mannequin was removed in 5 minutes. The total amount of water used by the sprays from these nozzles in 5 minutes was 75 litres. Figure 11(c) illustrates the typical evidence for a complete rinsing operation.

### Conclusions and Recommendations

Fine sprays can be used effectively in the treatment (coverage/deposition) section of a mass decontamination system with a suitable case, with no spill return, with 8 atomizers and individual flow rates of 0.55 l/min and at liquid pressure of 90 bar. It was found that water usage can be further reduced by using the spill return facility so that lower spray flow rates can be used but for a longer spraying period. One major benefit of this technology is the reduction in liquid consumption. This is also one of the major marketing points of this system over other available systems.

Future work will include studying the use of more than 8 atomizers but with reduced flow rates. Also the performance characteristics of the atomiser using different reagents in the water supply, must be determined. Generally the concentration of reagent used is low enough for the mixed liquid to be treated as water in terms of characteristics. Due to the various reagents that can be used, the reagent used could be introduced as a powder or as a liquid (in concentrate form or in aqueous solution).

Dynamic testing will be conducted to simulate practical situations since in the decontamination process a human has the ability to rotate in the chamber and thus fewer atomisers could be used.

A reduction of time in the rinsing stage could lead to the ability to decontaminate an increased number of people in an hour and also, more importantly, a further reduction in water flow rate.

The human body is also quite varied in terms of height and size. It would thus be a prudent to test the system on a wide range of people of different sizes and shapes. It may be that the decontamination procedure for a tall person would need to be modified so that their hands were within the spray pattern of the atomisers.

An automated system to detect people in the chamber could be installed to reduce the number of decontamination personnel needed at the decontamination site. Thus fewer PPE (Personal Protective Equipment)

suits would also need to be destroyed, as is the policy of some fire services and decontamination bodies.



(a) Before rinsing face and head

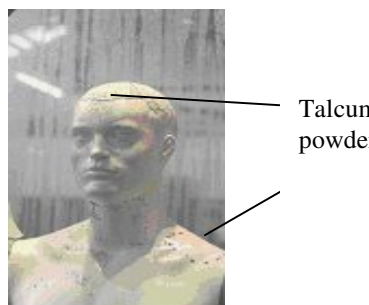

(b) 5min sprays with spill-return atomiser



(c) 5 min. rinse with HSS nozzle

Figure 11 Comparison of rinsing process using spill-return atomiser and Hughes safety nozzles

### References

- [1] Homeland Security Research Corporation, CBRN, Decontamination Industry Outlook, 2007-2012, Excerpts, 2004.
- [2] Larkin, M., Decontamination spray could save lives after bio terrorist attack, *The Lancet Infections Diseases*, Vol 3, June 2003.
- [3] Yule A.J., Nasr G.G. and Hughes T., Spray Device, Patent No. GB0625687.9, Dec. 2006.
- [4] Nasr G.G., Yule A.J., Lloyd S.E., The characterisation of the spray from a new fine spray spill return swirl atomizer, Proceedings of the 21<sup>st</sup> ILASS-Europe 2007.
- [5] Nasr G.G., Hughes T., Burby M., Yule A.J., The effectiveness and performance of nozzles in emergency safety showers, 15th ILASS-Europe Conference, Orleans, France, 2005.